

CLUTCH

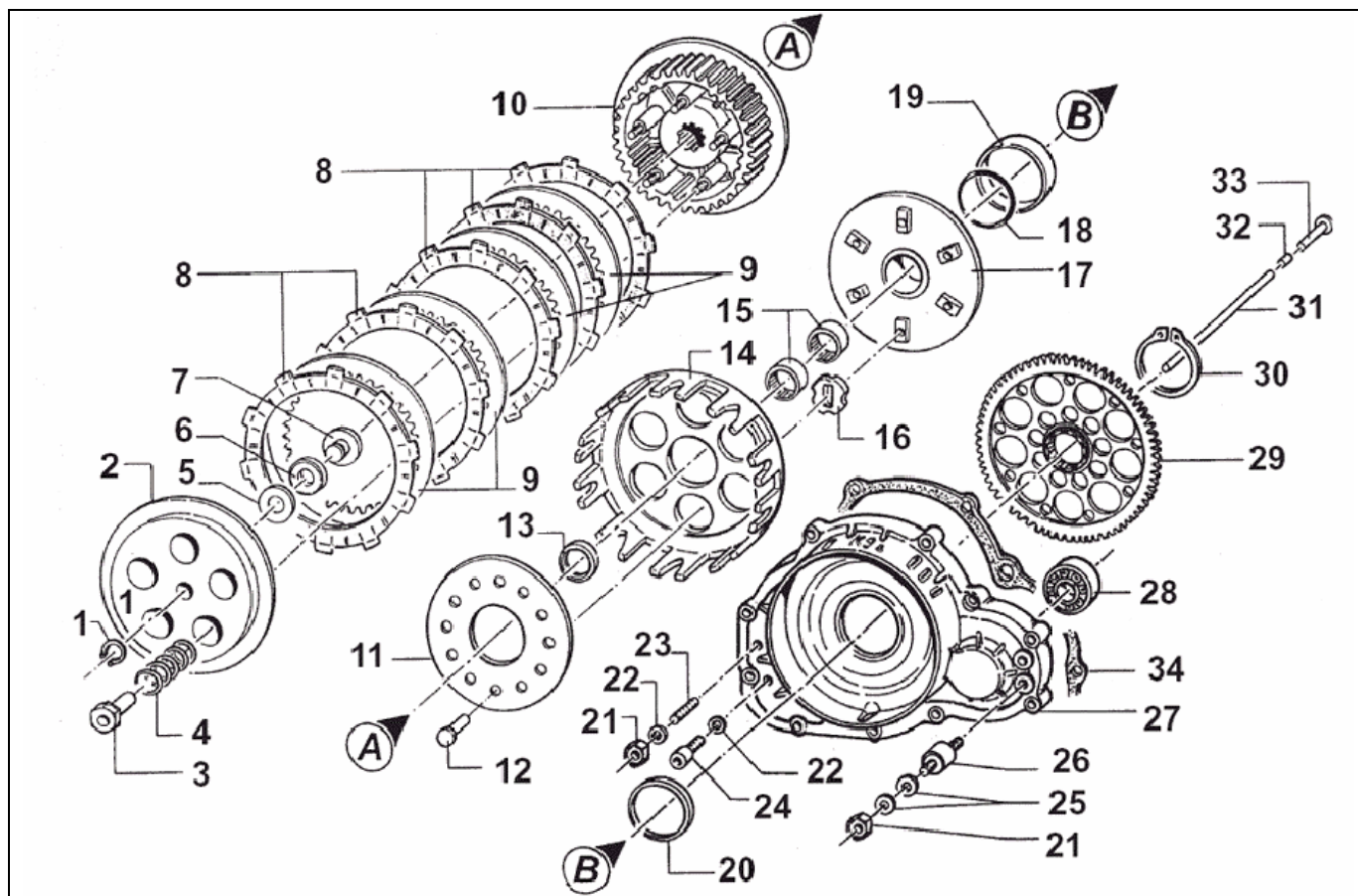

Nr	Description	Code
1	Snap ring	FB 142 2 0601 1
2	Plate, clutch pressure	FB 142 2 0602 1
3	Nut, clutch spring	FB 142 2 0603 1
4	Spring, clutch	FB 142 2 0604 1
5	Washer	FB 142 2 0605 1
6	Needle cage	FB 142 2 0606 1
7	Lifter, clutch	FB 142 2 0607 1
8	Clutch plate, fiber	FB 142 2 0608 1
9	Plate, steel 1.5mm	FB 142 2 0609 1
10	Clutch center	FB 142 2 0610 1
11	Plate	FB 142 2 0611 1
12	Stud Ø 6.9mm	FB 142 2 0612 1
13	Oil seal 20x26x4	FB 142 2 0613 1
14	Clutch basket	FB 142 2 0614 1
15	Needle cage HK 2012	FB 142 2 0615 1
16	Rubber	FB 142 2 0616 1
17	Plate, primary	FB 142 2 0617 1
	Plate, primary, complete	FB 142 2 0617 2

Nr	Description	Code
18	O-ring	FB 142 2 0618 1
19	Bushing	FB 142 2 0619 1
20	Oil seal 40 x 52 x7	FB 142 2 0620 1
21	Nut M6	FB 142 2 0621 1
22	Washer Ø 6mm	FB 142 2 0622 1
23	Grub screw M6 x 25	FB 142 2 0623 1
24	Screw M 6 x 10	FB 142 2 0624 1
25	Washer Ø 6mm	FB 142 2 0625 1
26	Rubber mount	FB 142 2 0626 1
27	Cover, clutch	FB 142 2 0627 1
28	Bearing 6202 C4	FB 142 2 0628 1
29	Primary gear Z 75	FB 142 2 0629 1
30	Snap ring	FB 142 2 0630 1
31	Clutch rod 145mm	FB 142 2 0631 1
32	Clutch pin	FB 142 2 0632 1
33	Clutch rod with button	FB 142 2 0633 1
34	Gasket, clutch over	FB 142 2 0634 1